

R. R. Usmanova, G. E. Zaikov, R. Ya. Deberdeev

## THE NEW EQUIPMENT FOR MODERNISATION OF SYSTEM OF CLEARING OF FLUE GASES

*Keywords: smoke fumes, dynamic separator, the industry, the baking oven, the plant flow diagram, bubbling-swirling apparatus, rotoklon, water recycling.*

*Gas-cleaning installations of a various principle of act are observed: rotational, impact-sluggish and centrifugal. Experiment by definition efficiency of clearing of gas emissions is executed. The characteristic for optimisation of hydrodynamic conditions of its work is given each aspect of scrubbers. It will allow designers of the equipment to make sampling of the necessary build. The modified row of apparatuses for wet clearing of gas emissions is devised. Designs on modernisation of system of clearing of smoke fumes of re-fire kilns are devised. Builds of apparatuses confirm the patent for an invention.*

*Ключевые слова: дымовые газы, динамический сепаратор, промышленность, печь, блок-схема завода, барботажно-вихревой аппарат, ротоклон, рециркуляция воды.*

*Проведен обзор газоочистных установок различного принципа действия: ротационных, инерционных и центробежных. Выполнен эксперимент по эффективности определения очистки газовых выбросов. Каждому элементу скрубберов дана характеристика для оптимизации гидродинамических условий. Это позволит разработчикам оборудования выбрать необходимую сборку. Разработан модифицированный ряд аппаратов для мокрой очистки газовых выбросов. Выполнены проекты по модернизации системы очистки дымовых газов печей. Новизна сконструированных аппаратов подтверждается патентами на изобретение.*

### 1. Introduction

The rapid development of the industry which have embraced in the second half of the XX-century many countries of the world, has led now to a serious decline of ecological situation. One of burning issues is pollution of air basin by gas emissions of the industrial factories. Growth of industrial outputs has served as the reason of increase in volumes of emissions in a circumambient. Working out of a considerable quantity of new processes promoted increase in quantity of the toxic substances arriving in an aerosphere. The problem of protection of a circumambient can be solved at the expense of a heading of the without waste, self-contained production engineering. However now this direction yet has not had sufficient development, therefore the problem of creation of the perfect and effective equipment for clearing of gas emissions of the industrial factories is actual.

The problem essentially becomes complicated that volumes of gas emissions of the industrial factories make tens, and sometimes and hundreds, thousand m<sup>3</sup>/h that does inconvenient application of the traditional clearing equipment. The majority of the apparatuses used now for clearing of gases from gaseous, liquid and firm impurity, are characterised by the low carrying capacity caused in the small maximum permissible speeds of gas in apparatuses. It serves as the reason of that high efficiency apparatuses have the big overall dimensions (for example, diameter of tower absorbers can attain 10 ÷ 12), and expenses for their manufacturing, installation and transportation are unreasonably great. Besides, in apparatuses of the big diameter it is impossible to achieve a liquid phase uniform distribution on their cross-section that leads to sharp decrease in efficiency of clearing.

The specified problems have served as the reason of that many industrial gas emissions at all are not exposed to clearing. As an example it is possible to result smoke gases of the factories of metallurgy, power

engineering, chemical, petrochemical and other industries, tank and scavenging gases of the various factories, emissions of a dust and steams of organic dissolvents in production areas of the factories.

The problem of clearing of great volumes of gas emissions of the industrial factories in an aerosphere can be solved for the account of application for these purposes of apparatuses of whirlwind type. Use in whirlwind apparatuses of centrifugal separation of phases removes restriction on maximum permissible speed of gas and allows to spend processes at the flow rate speeds of gas attaining 20-30 mps. High carrying capacity of whirlwind apparatuses causes their low metal consumption, rather small specific power expenses, simplicity of manufacturing. Design features of whirlwind apparatuses allow to spend to them complex clearing of gas emissions of the industrial factories as from harmful gaseous impurity, and of small liquid and firm corpuscles. Apparatuses also are rather convenient for conducting in them of process of vapour cooling of high-temperature gas emissions at a stage of preparation of gases to clearing.

In spite of the fact that a principle of a design of apparatuses of whirlwind type are developed for a long time, their wide use in the industry is restrained by an insufficient level of scrutiny hydro- and aerodynamic regularity of work and absence of reliable and well-founded methods of calculation of efficiency of processes of clearing of gas.

### 2. Engineering design and experimental researches of new apparatuses for gas clearing

#### 2.1 Apparatuses of impact-sluggish act

Mechanically each of such apparatuses consists of contact channel partially entrained in a liquid and the drop catcher merged in one body. The principle of act of apparatuses is based on a way of intensive washing of gases in contact channels of a various configuration

with the subsequent separation of a gas-liquid stream in the drop catcher.

The liquid which has thus reacted and separated from gas is not drained at once from the apparatus, and circulates in it and is repeatedly used in dust removal process. Circulation of a liquid in the wet-type collector occurs at the expense of a kinetic energy of a gas stream. Each apparatus is supplied by the device for maintenance of a fixed level of a liquid, and also the device for removal of sludge from the modular loading pocket of a scrubber.

Distinctive features of apparatuses:

1. Irrigation of gas by a liquid without use of injectors that allows to use for an irrigation a liquid with the high maintenance of suspended matters (to  $250 \text{ mg/m}^3$ );

2. The closed circulation of a liquid in apparatuses which allows to reuse a liquid in rotary connections of scrubbers and to scale down its charge on gas clearing in 10 and more times in comparison with other types of wet-type collectors;

3. Removal of the trapped dust from apparatuses in the form of dense sludges with low humidity that allows to simplify dust salvaging to reduce loading by water purification systems;

4. Configuration of the drop catcher in the body of the apparatus which allows to reduce sizes of dedusters to secure with their compactness.

The specified features and advantages of such scrubbers have led to wide popularity of these apparatuses, active working out of various builds, research and implementation of wet-type collectors, as in Russia, and abroad.

The investigated rotoklon (fig. 1) had 3 slot-hole channels speed of gas in which made to 15 mps. In the capacity of modelling system air and a talc powder have been used. The apparatus body was filled with water on level  $h_{\text{ж}}=0,175 \div 0,350 \text{ m}$ .

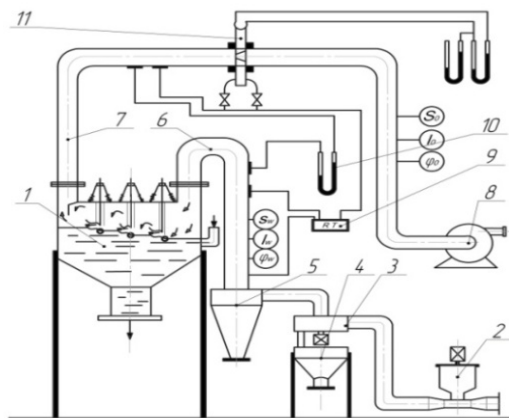

**Fig. 1 – The Circuit design of experimental installation: 1-rotoklon; 2 - the dust 2-batcher; 3 - qualifier; 4 - collector of a coarse dust; 5 - cyclone; 6,7-gas pipeline; 8 - the ventilating fan; 9 - potentiometer; 10 - differential pressure gauge; 11 - diaphragm**

Rotoklon works as follows.

Depending on a dust content dust gas a stream the top blades by means of screw lifts, and the bottom blades 6 by means of flywheels 8 are established on a corner defined by an operating mode of the device.

Dusty gas acts in an entrance branch pipe in the top part of the case of 1 device. Hitting about a surface of a liquid, it changes the direction. Owing to high speed of the movement, cleared gas grasps the top layer of a liquid and splits up him in the smallest drops and foam with an advanced surface.

The caught dust settles in the bunker to rotoklon and through a branch pipe for plum slime waters, together with a liquid, is periodically removed from the device

## 2.2 Apparatuses of rotational act

Dynamic gas washer, according to fig. 2, contains the vertical cylindrical case with the bunker gathering slime, branch pipes of input and an output gas streams.

Inside of the case it is installed conic vortex generator, containing.

Dynamic gas washer works as follows.

The Gas stream containing mechanical or gaseous impurity, acts on a tangential branch pipe in the ring space formed by the case and rotor. The liquid acts in the device by means of an axial branch pipe. at dispersion liquids the zone of contact of phases increases and, hence, the effective utilization of working volume of the device takes place more.

The Invention is directed on increase of efficiency of clearing of gas from mechanical and gaseous impurity due to more effective utilization of action of centrifugal forces and increase in a surface of contact of phases. The Centrifugal forces arising at rotation of a rotor provide crushing a liquid on fine drops that causes intensive contact of gases and caught particles to a liquid.

Owing to action of centrifugal forces, intensive hashing of gas and a liquid and presence of the big interphase surface of contact, there is an effective clearing of gas in a foamy layer. The water resistance of the irrigated apparatus at change of loadings on phases has been designed.

Considered angular speed of twirl of a rotor and veering of twirl of guide vanes of an air swirler.

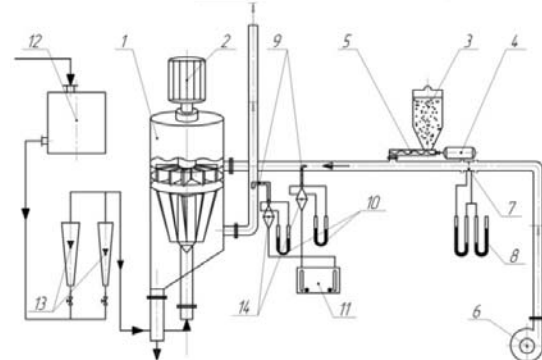

**Fig. 2 – the Circuit design of experimental installation: 1 - scrubber; 2 - the drive; 3 - the dust loading pocket; 4 - the electric motor; 5 - the batcher; 6 - the fan; 7 - a diaphragm; 8,10 - differenti 12 - the pressure tank; 13-rotametr; 14 - sampling instruments**

## 2.3 Bubbling - the vortical device

Experimental installation (a Fig. 3) has been devised. Experimental researches are directed on definition of effect of design data of an air swirler, a specific

irrigation, apparatus operating modes on aerodynamics of a gas-liquid stream and efficiency of clearing of gas emissions.

The Optimum mode of clearing of gas emissions can be achieved at application of the developed design bubbling - the vortical device providing a mode evaporation - condensation cooling and centrifugal wet dust-separation.

In bubbling - the vortical device before vortex generator a gas stream the central atomizer is installed, and in each flowing section after vortex generator peripheral atomizers are located.

Bubbling - the vortical device works as follows. Dusty gas moves in the cylindrical chamber on an entrance pipe where vortex generator by means of the blades forming flowing section, rejects a stream and gives to him rotary movement. Under action of centrifugal force arising at this disperse particles move to walls of the cylindrical chamber. For improvement of conditions of clearing of gases, before and after vortex generator are installed one central and four peripheral atomizers in which the irrigating liquid moves. The central atomizer installed before vortex generator, creates a volumetric torch atomization an irrigating liquid. At contact of the polluted gas and a liquid there is a partial evaporation of last and cooling of gas. The formed suspension is divided under action of the centrifugal force arising at rotation of a stream. The torch atomization the cooling liquid, formed by the central atomizer, (alongside with action of centrifugal forces) promotes outflow of disperse particles from the central zone of the cylindrical chamber that reduces a way of a particle up to a wall and reduces time of separation.

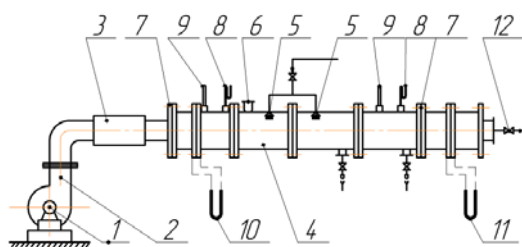

**Fig. 3 – The Circuit design of experimental installation:** 1 - electric motor; 2 - ventilating fan; 3 - hot-air heater; 4 - the whirlpool chamber; 5 - atomizers; 6 - loading pocket; 7 - diaphragm; 8,10 - differential pressure gauges; 9 - the thermometer; 11 - the fine gauge strainer; 12 - the coincidence gate

Technical and economic efficiency of use offered bubbling - the vortical device for clearing and cooling of smoke gases consists that he allows:

1. To increase efficiency dust separation due to installation in the device vortex generator a gas stream, the central and peripheral atomizers;
2. To lower hydraulic resistance of the device owing to a choice of optimum geometry of blades vortex generator;
3. To save material means and the areas of industrial premises due to an opportunity of installation bubbling - the vortical device in vent dust removal system.

### 3. Clearing of gases of a dust in the industry

The had results hardware in manufacture of roasting of limestone at conducting of redesign of system of an aspiration of smoke gases of baking ovens. The devised scrubber is applied to clearing of smoke gases of baking ovens of limestone in the capacity of a closing stage of clearing.

Temperature of gases of baking ovens in main flue gas breeching before a copper-utilizatorom 500-600 °C, after exhaust-heat boiler 250 °C. An average chemical compound of smoke gases (by volume): 17%CO<sub>2</sub>; 16%N<sub>2</sub>; 67 % CO. Besides, in gas contains to 70 mg/m<sup>3</sup> SO<sub>2</sub>; 30 mg/m<sup>3</sup> H<sub>2</sub>S; 200 mg/m<sup>3</sup> F and 20 mg/m<sup>3</sup> Cl. The gas dustiness on an exit from the converter reaches to 200/m<sup>3</sup> the Dust, as well as at a fume extraction with carbonic oxide after-burning, consists of the same components, but has the different maintenance of oxides of iron. In it than 1 micron, than in the dusty gas formed at after-burning of carbonic oxide contains less corpuscles a size less. It is possible to explain it to that at after-burning CO raises temperatures of gas and there is an additional excess in steam of oxides. Carbonic oxide before a gas heading on clearing burn in the special chamber. The dustiness of the cleared blast-furnace gas should be no more than 4 mg/m<sup>3</sup>. The following circuit design (fig. 4 see) is applied to clearing of the blast-furnace gas of a dust.

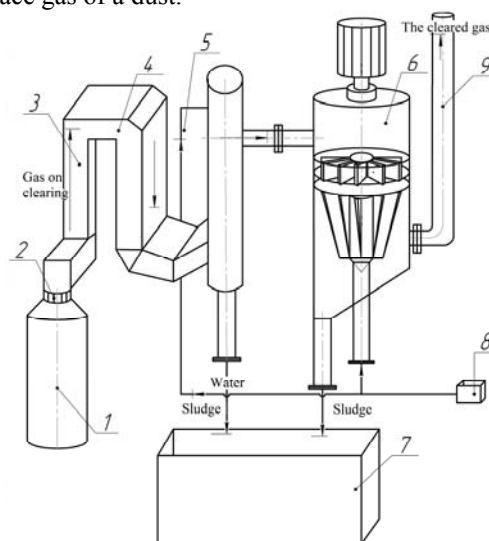

**Fig. 4 – Process flowsheet of clearing of gas emissions:** 1 - bake roasting; 2 - water block; 3 - raiser; 4 - downtaking duct, 5 - centrifugal scrubber; 6 - scrubber dynamic; 7 - forecastle of gathering of sludge, 8 - hydraulic hitch, 9 – chimney

Gas from a furnace mouth of a baking oven 1 on gas pipes 3 and 4 is taken away in the gas-cleaning plant. In raiser and downtaking duct gas is chilled, and the largest corpuscles of a dust which in the form of sludge are trapped in the inertia sludge remover are inferred from it. In a centrifugal scrubber 5 blast-furnace gas is cleared of a coarse dust to final dust content 5-10/m<sup>3</sup> the Dust drained from the deduster loading pocket periodically from a feeding system of water or steam for dust moistening. The final cleaning of the blast-furnace gas is carried out in a dynamic spray

scrubber where there is an integration of a finely divided dust. Most the coarse dust and drops of liquid are inferred from gas in the inertia mist eliminator. The cleared gas is taken away in a collecting channel of pure gas 9, whence is fed in an aerosphere. The clarified sludge from a gravitation filter is fed again on irrigation of apparatuses. The closed cycle of supply of an irrigation water to what in the capacity of irrigations the lime milk close on the physical and chemical properties to composition of dusty gas is applied is implemented. As a result of implementation of trial installation clearings of gas emissions the maximum dustiness of the gases which are thrown out in an aerosphere, has decreased with  $3950\text{mg/m}^3$  to  $840\text{ mg/m}^3$ , and total emissions of a dust from sources of limy manufacture were scaled down about 4800 to/a to 1300 to/a.

Such method gives the chance to make gas clearing in much smaller quantity, demands smaller capital and operational expenses, reduces an atmospheric pollution and allows to use water recycling system.

#### 4. Results of industrial tests of the gas-cleaning plant on the basis of device "rotoklon"

Let's consider system of wet clearing of the gases departing from the closed ferroalloy furnace 1. On this furnace comparative researches of the described system of wet dust separation (fig. 5 see) have been conducted.

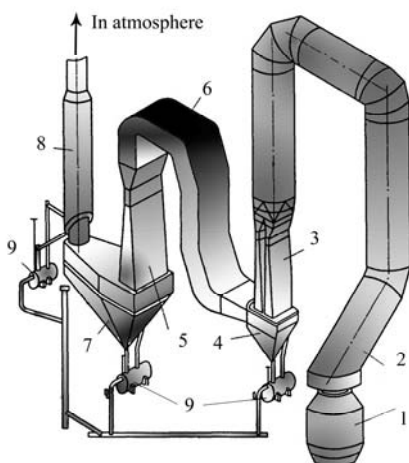

**Fig. 5 – The scheme of clearing of flue gas with gas cooling in a Venturi scrubber and the subsequent clearing in a rotoklon: 1 - baking oven; 2 - gas exit branch; 3 - Venturi scrubber; 4 - bunker - the drop catcher; 5 - rotoklon; 6 - gas pipeline; 7 - inertial heat - and a mist eliminator; 8 - exhaust pipe; 9 - tank - a hydraulic hitch**

The slope breeching 2, actually is the hollow scrubber in diameter of  $400\text{ mm}$  working in the evaporation cooling regime. At work gases arrive from it in a Venturi scrubber 3, consisting of two cylindrical columns in diameter of  $1000\text{ mm}$  with the general bunker. In each column of a scrubber it is established on three atomizers. The Venturi scrubber of the first step of clearing has a mouth in diameter of  $100\text{ mm}$  and is irrigated with water from an atomizer established in front of the confusor.

Gases after a slope breeching go at first to the bunker the drop catcher 4, and then in a rotoklon of the another step which consists from inertial a heat - and a mist eliminator 7. The exhaust of gases from the furnace is carried out by vacuum pump VVN-50 established behind devices of clearing of gas emissions. Purified gases are deduced in atmosphere.

Regulation of pressure of gases under a furnace roof and the expense of gases is carried out by a throttle in front of the vacuum pump. Slurry water from devices of clearing of gas emissions flows off a by gravity in a tank of a hydroshutter 9, whence also a by gravity arrives in a slurry tank. From a slurry tank water on two slurry clarifier is taken away on water purification. After clarification, chemical processing and cooling water is fed again by the pump on irrigating of gas-cleaning installations.

The dust containing in gases, differs high dispersion (to 80 weight. % of particles less than 5-6 microns). In table 1 the compound of a dust of exhaust gases is resulted.

**Table 1 – Results of posttest examination**

Compound	Requisite concentration, $\text{g/m}^3$	Concentration after clearing, $\text{g/m}^3$
Dust	0,02	0,00355
$\text{NO}_2$	0,10	0,024
$\text{SO}_2$	0,03	0,0005
CO	0,01	0,0019

In tests for furnaces almost constant electric regime that secured with identity of conditions at which parameters of systems of dust separation characterize was supported. The furnace worked on the fifth - the seventh steps of pressure at fluctuations of capacity 14,5-17,5 megawatt.

The quantity of dry gases departing from the furnace made  $1500\text{ }2000\text{ m}^3/\text{h}$ . The temperature of gases before clearing of gas emissions equaled  $750\text{ }850\text{ }^\circ\text{C}$ , and humidity did not exceed 4-5 % (on volume).

In table 2 results of calculation of a payment for pollutant emission of system of dust separation are shown:

Thus, we have chosen the scheme of clearing of gases which allows to lower concentration of pollutants to preset values and consequently, and to lower payments by the enterprise for emissions.

#### 5. Industrial application of vortical devices

It is settlement - theoretical and design - design works were carried out with reference to operating conditions of manufacture hypochlorite calcium of Joint-Stock Company «Caustic»

On Joint-Stock Company «Caustic » the device is offered to be used for clearing smoke gases of furnaces of roasting 1 (fig. 6 see).

According to the technological scheme, departing from the furnace of roasting 1 gases at temperature  $550^\circ\text{C}$  act in the bubbling-vortical device 2. Here on an irrigation 1-3 % a solution of limy milk ( $\text{pH} = 11,5 - 12,5$ ) move. Separated slime acts in a drum - slake 3; clarification and cooling of limy milk happens in the filter-sediment bowl 4: from which it feed on irrigation.

The cleared gas stream smoke exhauster 7 is thrown out in an atmosphere.

**Table 2 – Results of calculation of a payment for pollutant emission**

The list of pollutants (the substance name)	It is thrown out for the accounting period, t/year		The base specification of a payment within admissible specifications, a Russian rouble/t	
	In total	Including VPE MPE		
1	2	3	4	5
The inorganic Dust	19 710		-	21
nitrogen dioxide	105,1		-	52
carbon monoxide	288,2		-	0,6
Sulfurs dioxide	197,1		-	40
Total:				
The list of pollutants (the substance name)	The size of a payment for a maximum permissible emission, Russian rouble/year	The base specification of a payment within the established limits, a Russian rouble/t	Total a payment on the enterprise, a Russian rouble/year	
The inorganic Dust	228,65	105	228,65	
nitrogen dioxide	379,19	260	379,19	
carbon monoxide	2,99	3	2,99	
Sulfurs dioxide	539,14	200	539,14	
Total:	1149,97		1149,97	

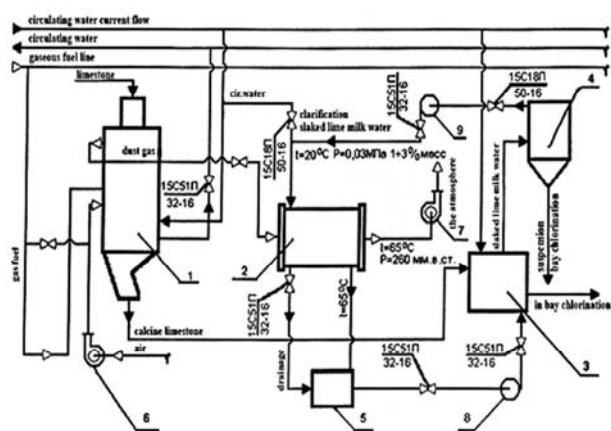

**Fig. 6 – Flowchart of clearing of gas emissions**

Thus, introduction bubbling - the vortical device will allow to solve a problem of clearing of smoke gases with return of all caught dust in the form of slime

in branches of slaking lime, that provides captives manufactures.

Bubbling - the vortical device is supposed to mount in vent dust removal systems with the purpose of economy of the areas of industrial premises, thus hydraulic resistance of system does not exceed 500 Pascal, power inputs on clearing of gas in 3 times below, than in known devices.

Application bubbling - the vortical device allows to achieve an intensification of process of gas purification with reduction of a gassed condition of air pool.

### 6. The modified variety of apparatuses

By results of research the industrial modified rows of apparatuses in diameter from 0,8 to 1,5 m. Apparatuses are devised secure with clearing of gases over the range productivity from 500 till 22000 m<sup>3</sup>/hour. Apparatuses are introduced in the capacity of the another echelon of wet clearing of gas emissions in manufacture of hypochlorite of calcium for clearing of a waste-heat of a limestone refire kiln; in burning department for clearing of smoke fumes of a refire kiln of a barite; in commodity output department.

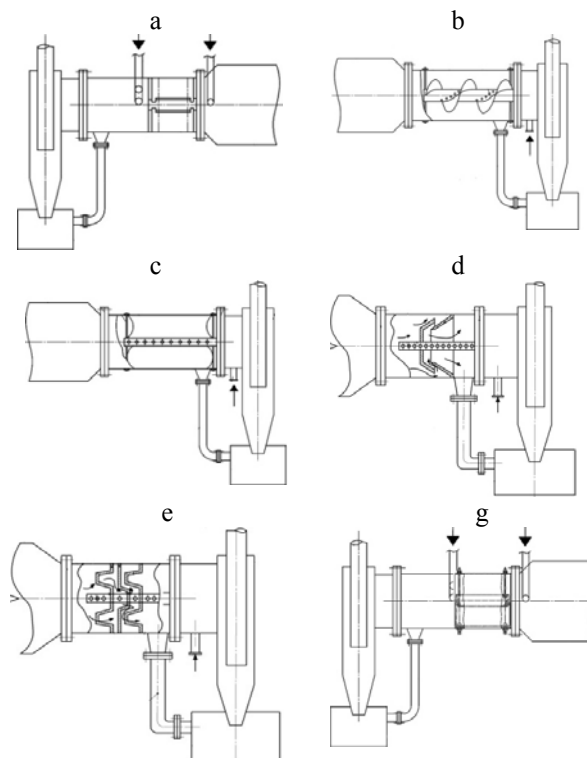
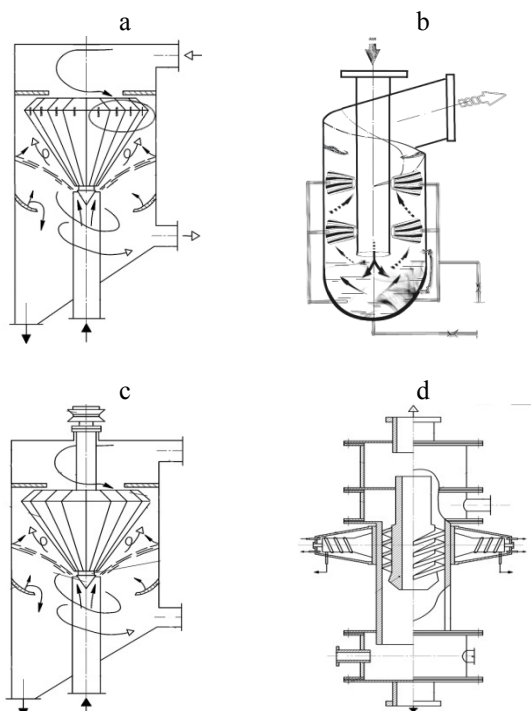

**Fig. 7 – The modified variety of apparatuses under patents for inventions: a) №2182843; b) № 2305457; c) № 316383; d) № 2382680; e) № 2403951; g) № 2234358**

Distinctive feature of offered systems is realization closed loop system smoke sucker - Bubbling - the vortical device - a cyclone and retrace of the trapped product to technological manufacture. It is necessary to note simplicity of a design and maintenance of apparatuses, and also betterment of work of the flue-gas pump (the vane wheel rotor and the body are not choked) along with high separation efficiency of gases. Besides, the apparatus has indisputable advantage when the



deduster should place in gas pipes for the factories with the restricted floor spaces. The rational values of parametres of a dynamic spray scrubber had in-process are implemented in type apparatuses: a scrubber. Results of work have been used at designing of gas-cleaning plants of some industrial productions.



**Fig. 8 – The modified variety of apparatuses scrubber under patents for inventions: a) Patent decision № 2012153318/15; b) Patent decision № 2012157446/15; c) № 2339435; d) № 2482923**

The complex of the spent researches has formed the basis for designing of system of air purification of production areas. The had results have been almost implemented in commodity output manufacture. The apparatus is resistant to against oscillations both the general loading, and a relationship of gas rates. One of the major advantages of configuration of systems clearings of gas emissions "Rotoklon" is possibility of the closed cycle of an irrigation thanks to system internal circulation of a liquid in the apparatus.

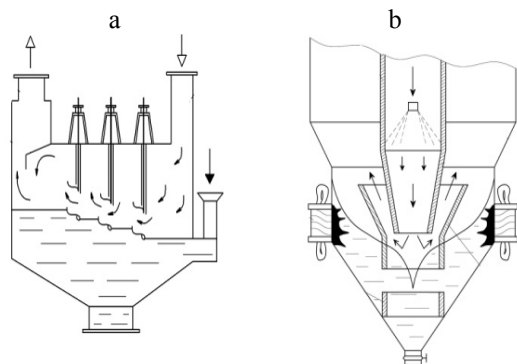

**Fig. 9 – The modified variety of apparatuses "Rotoklon" under patents for inventions: a) № 2317845; b) The request №2007120000**

Recommendations about rational designing of dust removal apparatuses are devised. By results of work it is introduced in various manufactures more than 10 dedusters. Economic benefit of implementation of systems and recommendations has made more than 3 million roubles/years.

## 7. Conclusions

1. The solution of an actual problem on perfection of complex system of clearing of gas emissions and working out of measures on decrease in a dustiness of air medium of the industrial factories for the purpose of betterment of hygienic and sanitary conditions of work and decrease in negative affecting of dust emissions on a circumambient is in-process given.

2. Designs on modernisation of system of an aspiration of smoke gases of baking ovens of limestone with use of the new scrubber which novelty is confirmed with the patent for the invention are devised. Efficiency of clearing of gas emissions is raised. Power inputs of spent processes of clearing of gas emissions and power savings at the expense of modernisation of a flowchart of installation of clearing of gas emissions are lowered.

3. The modified variety of apparatuses for wet clearing of the gas emissions which have confirmed high separation efficiency both in laboratory, and in industrial conditions. The ecological result of implementation of systems and recommendations consists highly clearings of a waste-heat and betterment of ecological circumstances in a zone of the factories. Economic benefit of implementation has made more than 3 million rouble/year

## References

1. Usmanova, R.R. Bubbling - the vortical device. The patent of the Russian Federation the invention №2182843. 27 May **2002**. The bulletin.№15.
2. Usmanova, R.R. Bubbling - the vortical device with adjustable blades. The patent of the Russian Federation the invention №2234358. 20 August **2004**. The bulletin.№23.
3. Usmanova, R.R. Bubbling - the vortical device with an axial sprinkler. The patent of the Russian Federation the invention №2316383. 10 February **2008**. The bulletin .№4.
4. Usmanova, R.R. Rotoklon with adjustable sine wave blades. The patent of the Russian Federation the invention № 2317845 27 February **2008**. The bulletin .№6.
5. Usmanova, R.R. Bubbling-swirling apparatus with parabolic swirler. The patent of the Russian Federation the invention № 2382680, 27 February **2010**. The bulletin .№6.
6. Usmanova, R.R. Bubbling-swirling apparatus with conical swirler. The patent of the Russian Federation the invention №2403951, 20 November **2010**. The bulletin .№32.
7. Usmanova, R.R. Dynamic gas washer. The patent of the Russian Federation the invention №2339435. 20 November **2008**. The bulletin .№33.
8. Usmanova, R.R. The whirlwind apparatus with application of ultrasonic vibrations. The patent of the Russian Federation the invention №2482923. 27 May **2013** The bulletin .№15.
9. Usmanova, R.R. Scrubber. Patent decision № 2012153318/15 From 07.02.2014.
10. Usmanova, R.R. Hydrodynamic deduster. Patent decision № 2012157446/15 From 24.02.2014.